

L形集水桝縁塊（東京都型）

(断面図)

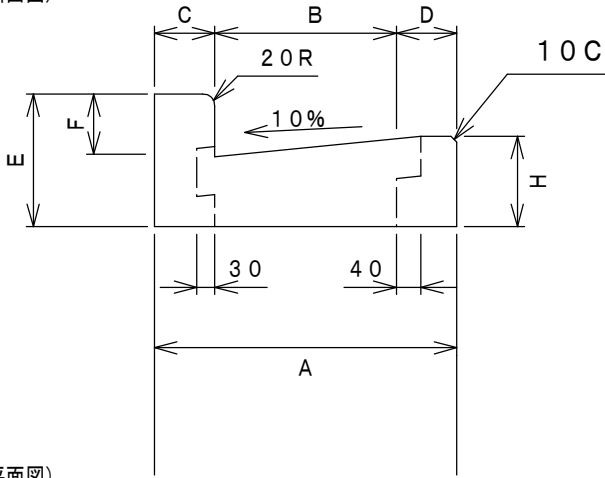

(断面図)

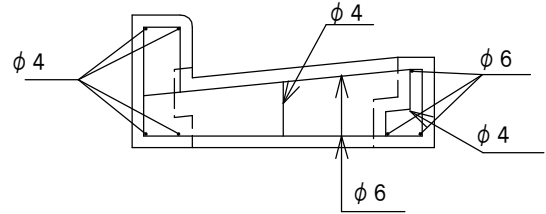

(平面図)

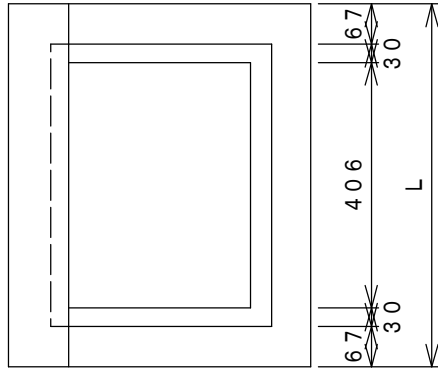

(平面図)

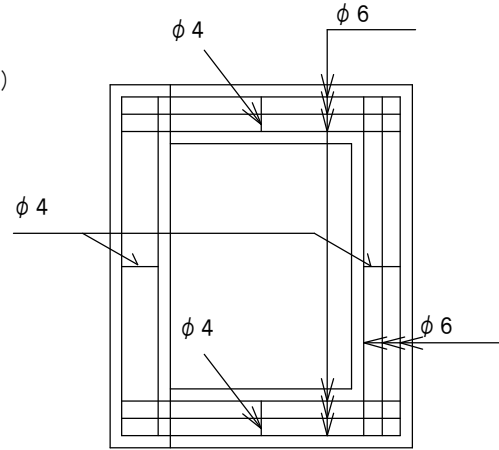

呼び名	寸法表 (mm)								重量 (Kg)
	A	B	C	D	E	F	H	L	
250	450	250	100	100	220	100	150	600	63
250 (平H50)	450	250	100	100	170	50	150	600	58
250 (平H20)	450	250	100	100	140	20	150	600	54
300	500	300	100	100	220	100	155	600	66
300 (平H50)	500	300	100	100	170	50	155	600	60
300 (平H20)	500	300	100	100	140	20	155	600	56
350	550	350	100	100	220	100	160	600	70
350 (平H50)	550	350	100	100	170	50	160	600	62
許容差 (mm以内)	±2	—	±2	—	±3	±2	±3	±3	