

鋼板巻ロングU ダクティルグレーチング付 (T-25) 400×400~1200

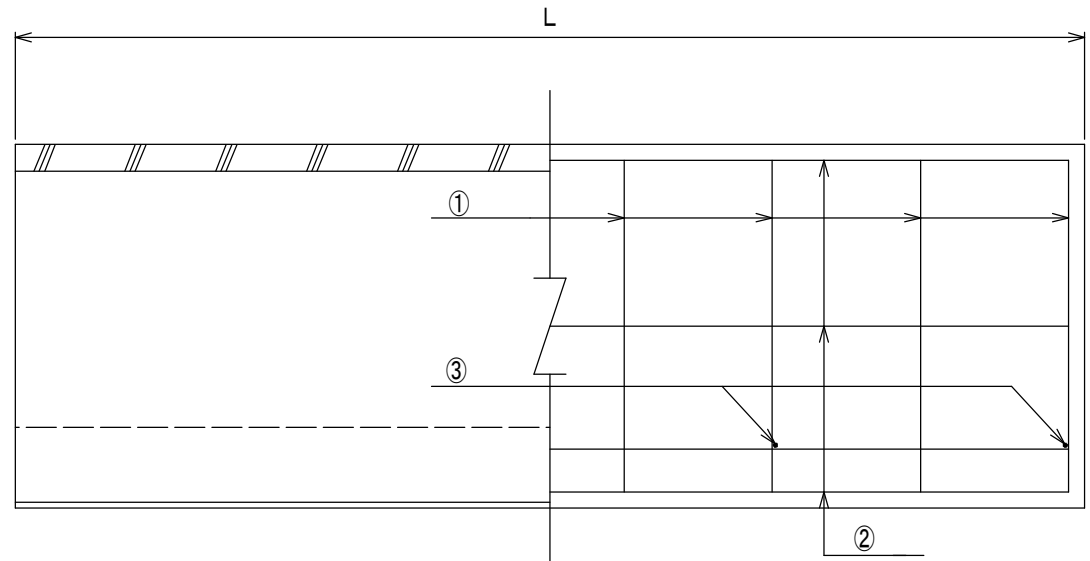

呼び名	寸法 (mm)										配筋 (径*本数)			重量 (Kg)
	A	a1	b	c	d	e	f	H	h1	L	①	②	③	
400×400	400	700	380	55	95	50	150	480	680	2000	φ5-10	φ5-9	D10-6	1301
400×500	400	700	375	55	95	50	150	580	780	2000	φ5-10	φ5-11	D10-6	1451
400×600	400	700	370	55	95	50	150	680	880	2000	φ6-10	φ5-11	D10-6	1631
400×700	400	700	365	55	95	50	150	780	980	2000	D10-8	φ6-11	D10-6	1794
400×800	400	700	360	55	95	50	150	880	1080	2000	D10-8	φ6-13	D10-8	1960
400×900	400	700	355	55	95	50	150	980	1180	2000	D10-8	φ6-13	D10-8	2128
400×1000	400	700	350	55	95	50	150	1080	1280	2000	D10-10	φ6-13	D10-10	2298
400×1100	400	700	345	55	95	50	150	1180	1380	2000	D10-10	φ6-15	D10-10	2470
400×1200	400	700	340	55	95	50	150	1280	1480	2000	D10-12	φ6-15	D10-12	2644
許容差 (mm以内)	±3	±6	±3	±3	±3	±3	±3	±3	±6	±6				

目地詳細 (mm)

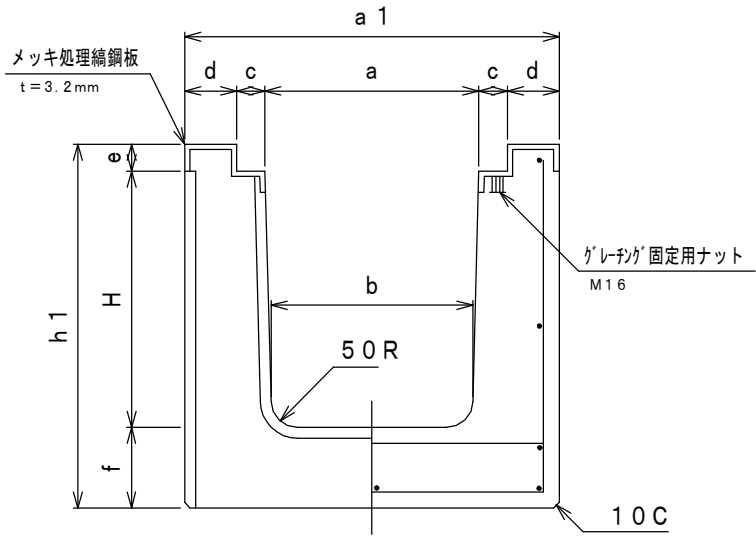