

鋼板巻ロングU トライポットグレーチング付 (T-25) 600×600~1300

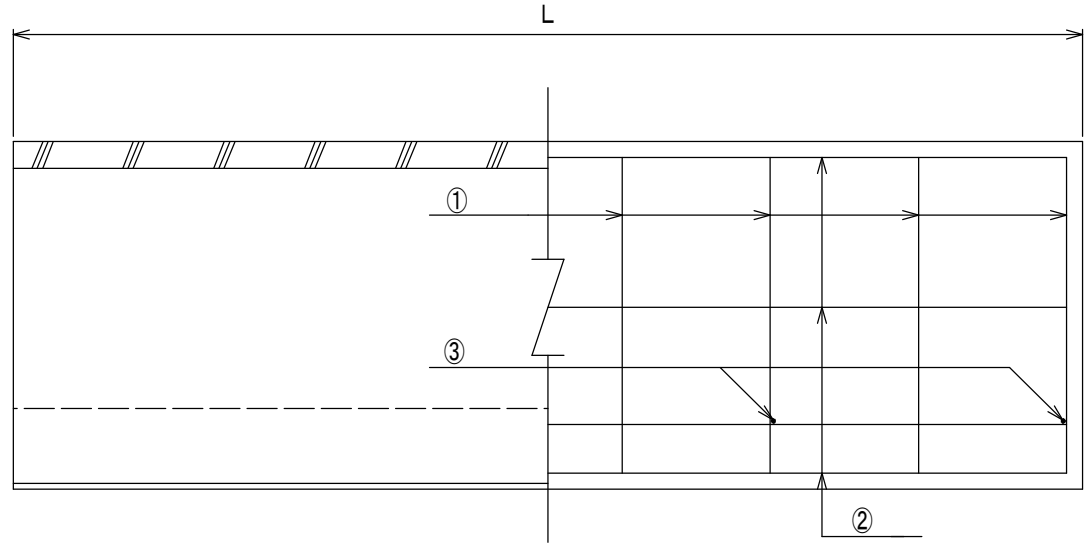

呼び名	寸法 (mm)										配筋 (径*本数)			重量 (Kg)
	A	a1	b	c	d	e	f	H	h1	L	①	②	③	
600×600	600	900	570	52	98	65	150	685	900	2000	φ6-10	φ6-12	D10-6	1783
600×700	600	900	565	52	98	65	150	785	1000	2000	φ6-10	φ6-12	D10-6	1962
600×800	600	900	560	52	98	65	150	885	1100	2000	D10-8	φ6-14	D10-8	2128
600×900	600	900	555	52	98	65	150	985	1200	2000	D10-8	φ6-14	D10-8	2295
600×1000	600	900	550	52	98	65	150	1085	1300	2000	D10-10	φ6-14	D10-10	2466
600×1100	600	900	545	52	98	65	150	1185	1400	2000	D10-10	φ6-16	D10-10	2639
600×1200	600	900	540	52	98	65	150	1285	1500	2000	D10-12	φ6-16	D10-12	2814
600×1300	600	900	535	52	98	65	150	1385	1600	2000	D10-12	φ6-16	D10-12	2991
許容差 (mm以内)	±3	±6	±3	±3	±3	±3	±3	±3	±6	±6				

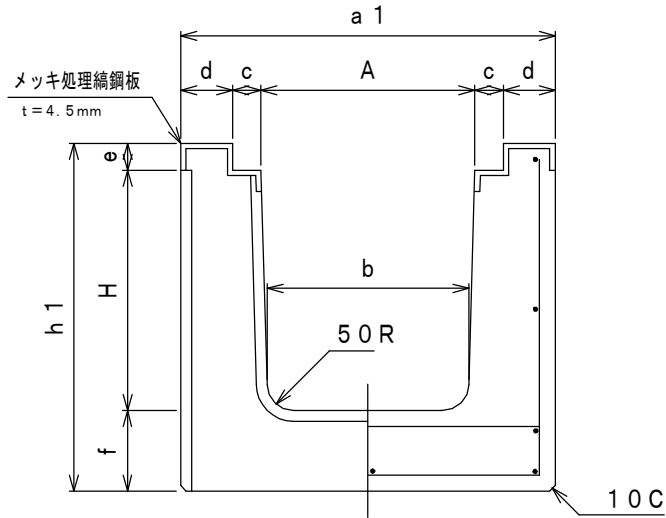